

VC-20-PRJ25 **IMBE™ Vocoder Board** **User's Manual**

Version 2.0

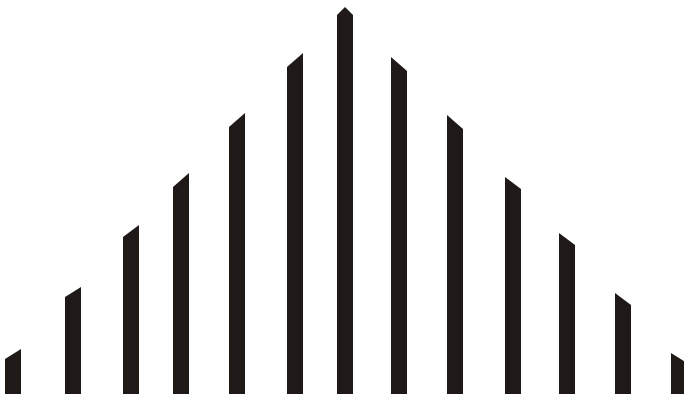

VC-20-PRJ25 IMBE™ Vocoder Board

User's Manual

Version 2.0

Copyright ©, 1998
Digital Voice Systems, Inc
234 Littleton Raod
Westford, MA 01886

This document may not, in whole or in part be copied, photocopied, reproduced, translated, or reduced to any electronic medium or machine readable form without prior consent in writing from Digital Voice Systems, Incorporated.

Every effort has been made to ensure the accuracy of this manual. However, Digital Voice Systems, Inc. makes no warranties with respect to the documentation and disclaims any implied warranties of merchantability and fitness for a particular purpose. Digital Voice Systems, Inc. shall not be liable for any errors or for incidental or consequential damages in connection with the furnishing, performance, or use of this manual or the examples herein. The information in this document is subject to change without notice.

Trademarks

VC-20 IMBE™ Vocoder Board is registered trademarks of Digital Voice Systems, Inc. Other product names mentioned may be trademarks or registered trademarks of their respective companies and are the sole property of their respective manufacturers.

All Rights Reserved
Data subject to change

VC-20-PRJ25 IMBE™ Vocoder Board END USER License Agreement

1.0 Preliminary Statements and Definitions

1.1 "Voice Codec" shall mean the hardware, software and associated documentation referred to in the invoice or shipping papers accompanying this agreement for which END USER has requested a license, and any derivative works thereof, including modifications, enhancements and extensions made by or for Digital Voice Systems, Inc. (DVSI) and including circuit diagrams, timing diagrams, programmable logic software, logic diagrams, layouts, operating instructions and user manuals.

1.2 "IMBE™ Software" shall mean the speech coding software and/or firmware provided as part of the Voice Codec. This software is contained in the Read Only Memories (ROMS, EPROMS, EEPROMS, etc...) which are included as part of the Voice Codec. This software includes any derivative works which have as their source the software contained in the Read Only Memories, and it includes the software contained in any future Read Only Memories which DVSI may provide END USER for use in the Voice Codec.

1.3 "Designated Site" shall mean the location of the Voice Codec.

1.4 "Proprietary Information" shall mean the information which DVSI desires to protect against unrestricted disclosure or competitive use and which is designated as such in writing by DVSI or is disclosed orally and within thirty (30) days thereafter is reduced to tangible form pursuant to this License.

1.5 DVSI represents that it owns certain "Proprietary Rights" in the Technology and the IMBE® Voice Compression Software, including patent rights in the Technology, and patent rights, copyrights, and trade secrets in the IMBE® Voice Compression Software.

2.0 License Granted

2.1 Subject to the conditions herein and upon initial use of the IMBE™ Software within the VC-20 IMBE™ Vocoder Codec, DVSI hereby grants to END USER a non-exclusive, limited license to use the IMBE® Voice Compression Software in machine readable form solely on the IMBE-1000™ Vocoder Chip. Title to the IMBE® Voice Compression Software remains with DVSI. No license is granted for use of the IMBE® Voice Compression Software on other than the Voice Codec. No license, right or interest in any trademark, trade name or service mark of DVSI is granted under this Agreement.

2.2 END USER shall not copy, extract, de-compile, reverse engineer or disassemble the IMBE® Voice Compression Software contained in the VC-20 IMBE™ Vocoder Board.

2.3 Transfer of License

(a) END USER may transfer the IMBE™ Software and all rights under this agreement to a third party together with a copy of this Agreement provided that END USER provides DVSI with a written notification of the transfer and provided that the third party agrees in writing to accept all the terms and conditions of this

agreement. Upon any such transfer, END USER's rights under this Agreement shall terminate pursuant to Section 3.0.

(b) END USER may relocate the Voice Codec, and the subsequent location shall then be considered the Designated Site.

(c) Except as provided in this Section 2.2, this Agreement, the IMBE™ Software and any other information provided by DVSI to END USER and any licenses and rights granted hereunder, may not be sold, leased, assigned, sublicensed or otherwise transferred, in whole or in part, by END USER.

2.4 END USER shall not de-compile, reverse engineer or disassemble the IMBE™ Software.

3.0 Term and Termination

3.1 This Agreement is effective upon initial use of the IMBE™ Software on the Voice Codec and shall remain in effect until terminated in accordance with this agreement.

3.2 This Agreement shall terminate automatically without notice from DVSI if END USER fails to comply with any of the material terms and conditions herein. END USER may terminate this Agreement at any time upon written notice to DVSI certifying that END USER has complied with the provisions of Section 3.3.

3.3 Upon termination of this Agreement for any reason, END USER shall: (i) have no further rights to the IMBE™ Software; (ii) discontinue all use of the IMBE™ Software; and (iii) destroy or, at DVSI's option, return all copies of the IMBE™ Software.

4.0 Payments

4.1 In consideration of the hardware, software, and associated materials provided as part of the Voice Codec, and in consideration of the license and rights in the IMBE™ Software granted by DVSI, and in consideration of DVSI's performance of its obligations hereunder, END USER agrees to pay to DVSI the fee specified in DVSI's invoice.

4.2 In consideration of the materials provided as part of the Voice Codec, and in consideration of the license and rights in the IMBE® Voice Compression Software granted by DVSI, and in consideration of DVSI's performance of its obligations hereunder, END USER agrees to pay to DVSI the fee specified in DVSI's invoice.

5.0 Proprietary Notices

5.1 END USER shall not remove any copyright or proprietary notice on the on the IMBE® Voice Compression Software or VC-20 IMBE™ Vocoder Board.

6.0 Proprietary Information

6.1 The parties agree that the IMBE® Voice Compression Software shall be considered Proprietary Information.

6.2 Except as otherwise provided in this Agreement, END USER shall not use, disclose, make, or have made any copies of the Proprietary Information, in whole or in part, without the prior written consent of DVSI.

6.3 END USER shall make reasonable efforts to notify and inform its employees having access to the Proprietary Information of END USER's limitations, duties and obligations regarding nondisclosure and copying of the IMBE™ Software. Proprietary Information shall be used only by employees of END USER and only at the Designated Site, except as provided under this agreement.

6.4 END USER shall have no obligations for disclosure or use of Proprietary Information which: (i) is already known to END USER, at time of disclosure by DVSI; (ii) is or becomes publicly known through publication, inspection of product or otherwise through no wrongful act of END USER; (iii) is received from a third party without restriction and without breach of this Agreement; (iv) is independently developed by END USER; (v) is disclosed to a third party by or on behalf of DVSI without restriction; or (vi) is approved for release or use by written authorization of DVSI.

6.5 Notwithstanding any termination pursuant to Section 3.0, the obligations set forth in this Section 6.0 shall survive termination of this Agreement.

7.0 Limited Warranty

7.1 DVSI warrants the Voice Codec and the IMBE™ Software to be free from defects in materials and workmanship under normal use for a period of ninety (90) days from the date of delivery. DVSI further warrants that the Voice Codec and the IMBE™ Software operate in accordance with the written specifications delivered to END USER with the Voice Codec.

7.2 Except as stated in Section 7.1, the Voice Codec and IMBE™ Software are provided "as is" without warranty of any kind. DVSI does not warrant, guarantee or make any representations regarding the use, or the results of the use, of the Voice Codec or IMBE™ Software with respect to its correctness, accuracy, reliability, currentness or otherwise. The entire risk as to the results and performance of the Voice Codec or IMBE™ Software is assumed by the END USER. After expiration of the warranty period, END USER, and not DVSI or its employees, assumes the entire cost of any servicing, repair or correction of the Voice Codec or the IMBE™ Software.

7.3 DVSI warrants that it has the right to enter into this Agreement and to grant a license to use the IMBE™ Software to END USER.

7.4 Except as specifically set forth in this Section 7.0, DVSI makes no express or implied warranties including, without limitation, the warranties of merchantability or fitness for a particular purpose or arising from a course of dealing, usage or trade practice, with respect to the Voice Codec or IMBE™ Software. Some states do not allow the exclusion of implied warranties, so the above exclusion may not apply to END USER. No oral or written information or advice given by DVSI or its employees shall create a warranty or in any way increase the scope of this warranty, and END USER may not rely on any such information or advice. The limited warranties under this

section 7.0 give END USER specific legal rights, and END USER may have other rights which vary from state to state.

8.0 Limitation of Liability

8.1 In no event shall DVSI be liable for any special, incidental, indirect or consequential damages resulting from the use or performance of the Voice Codec or VC-20 IMBE™ Vocoder Board whether based on an action in contract, tort (including negligence) or otherwise (including, without limitation, damages for loss of business profits, business interruption, and loss of business information), even if DVSI or any DVSI representative has been advised of the possibility of such damages.

8.2 Because some states do not allow the exclusion or limitation of liability for consequential or incidental damages, the above limitations may not apply to END USER.

8.3 DVSI's maximum liability for damages arising under this Agreement shall be limited to 20% (twenty percent) of the fees paid by END USER for the particular Voice Codec or VC-20 IMBE™ Vocoder Board which caused the damages or that is the subject matter of, or is directly related to, the cause of action.

9.0 Taxes

9.1 All payments required under Section 4.0 or otherwise under this Agreement are exclusive of taxes and END USER agrees to bear and be responsible for the payment of all such taxes (except for taxes based upon DVSI's income) including, but not limited to, all sales, use, rental receipt, personal property or other taxes which may be levied or assessed in connection with this Agreement.

10.0 Export

10.1 United States export laws and regulations prohibit the exportation of certain products or technical data received from DVSI under this Agreement to certain countries except under a special validated license. As of May 20, 1996 the restricted countries are: Libya, Cuba, North Korea, Iraq, Serbia, Montenegro, and Iran. The END USER hereby gives its assurance to DVSI that it will not knowingly, unless prior authorization is obtained from the appropriate U.S. export authority, export or re-export, directly or indirectly to any of the restricted countries any products or technical data received from DVSI under this Agreement in violation of said United States Export Laws and Regulations. DVSI neither represents that a license is not required nor that, if required, it will be issued by the U.S. Department of Commerce. Licensee shall assume complete and sole responsibility for obtaining any licenses required for export purposes.

11.0 Governing Law

11.1 This Agreement is made under and shall be governed by and construed in accordance with the laws of the Commonwealth of Massachusetts, except that body of law governing conflicts of law. If any provision of this Agreement shall be held unenforceable by a court of competent jurisdiction, that provision

shall be enforced to the maximum extent permissible, and the remaining provisions of this Agreement shall remain in full force and effect.

12.0 Notices

12.1 Any notices to DVSI which may be given hereunder shall be in writing and sent to: Digital Voice Systems Inc., 234 Littleton Road, Westford, MA., 01886, U.S.A.

TABLE OF CONTENTS

Section 1	PRODUCT INTRODUCTION	1
	GENERAL INFORMATION.....	1
Section 2	VC-20-PRJ25 IMBE™ VOCODER OPERATION	2
	OPERATION	2
Section 3	TECHNICAL SPECIFICATIONS	3
	VC-20-PRJ25 CONNECTOR SIGNAL DESCRIPTIONS	6
Section 4	TECHNICAL DRAWINGS	10
Section 5	DVSI SUPPORT SERVICES	16
	TECHNICAL SUPPORT	16

LIST OF FIGURES

Figure 1	Silence / Voice Frame Signaling	9
Figure 2	VC-20-PRJ25 Connections In Loop-Back Mode.....	15
Figure 3	Connections between VC-20-PRJ25 and a Modem	16
Figure 4	Dual VC-20- PRJ25 Vocoder Board Connections	17
Figure 5	VC-20- PRJ25 Channel Signal Timing Relationships.....	18
Figure 6	Run Signal Timing	20
Figure 7	VC-20-PRJ25 Physical Dimensions	21

SECTION 1

Product Introduction

General Information

The Digital Voice Systems, Inc. (DVSI) VC-20-PRJ25 voice codec is a full-duplex real-time voice processing board. The VC-20-PRJ25 contains proprietary software which implements the Improved Multi-Band Excitation™ (IMBE™) voice coding algorithm. DVSI grants a license to its customers to use this software according to the terms established in the attached IMBE™ Software END USER License Agreement. Use of the VC-20-PRJ25, or any portion thereof, signifies acceptance of these licensing terms.

The VC-20-PRJ25 operates by digitizing an analog speech signal using an on-board A-to-D converter. This digitized speech is then processed by the encoder and converted into a 7.2 kbps data bit stream. This bit stream is output to a modem or similar device. Simultaneously, the VC-20-PRJ25 receives a 7.2 kbps data bit stream from a modem or similar device. This received bit stream is processed by the decoder and converted into a synthetic speech signal which is then converted into an analog signal using the on-board D-to-A converter. The encoder and decoder are fully asynchronous

The VC-20-PRJ25 is capable of supporting advanced features such as external codecs and downloading custom software. Please contact DVSI for more information on these features.

SECTION 2

VC-20-PRJ25 IMBE™ Vocoder Operation

Operation

Connections are made to the VC-20-PRJ25 using the attached DIN 41612 connector which is described in Sections 4 and 5. The user must supply the VC-20-PRJ25 with a 5v digital power supply and a +/-5v analog power supply. It is preferable to decouple the analog supply from the digital supply by using separate power supplies. The VC-20-PRJ25 contains one set of jumpers which is used to loop-back the encoder signals to the decoder, and to enable the on-board clocks and frame signals. The pin assignment for this jumper is documented in Section 7

The VC-20-PRJ25 can be operated in loop-back mode by using the internal clock and frame generator to generate the clock signals, TXCK and RXCK, and the frame signals, FMEN and FMDE, as shown in Figure 2. Jumpers 1-12 on the fourteen pin jumper block should be connected and all other jumpers should be disconnected.

The VC-20-PRJ25 can be connected to a modem or similar device as shown in Figure 3. The modem or the VC-20-PRJ25 can generate the clock and framing signals TXCK, FMEN, RXCK and FMDE. The modem reads the data from the encoder on the data lines QTXD, ITXD, and ENSLNCE. Simultaneously the decoder reads data from the modem on data lines QRXD, QRXD1, QRXD0, IRXD, IRXD1, IRXD0, DESLNCE, HD_SD and LOST. Note: if soft-decision information is unavailable, then the HD_SD signal should be held high (or left unconnected) so that only the MSB data signals (QRXD, IRXD) will be read by the decoder. The frame signals FMEN and FMDE are used to signify the beginning of each data frame for the encoder and decoder, respectively. The required timing relationship between these signals is shown in Figure 5. In order to operate in this mode, jumpers 5-10 and 12-14 should be disconnected. If the VC-20-PRJ25 is generating the clocks and frames, then jumpers 1-4 should be connected, otherwise, they should be disconnected. Jumper 11 is disconnected if the LOST signal is used, otherwise it is connected.

A final operating mode allows two VC-20-PRJ25's to be connected together using their on-board clocks to generate the signals TXCK, FMEN, RXCK and FMDE. In this mode the encoder on the first VC-20-PRJ25 is connected to the decoder on the second VC-20-PRJ25. Similarly, the decoder on the first VC-20-PRJ25 is connected to the encoder on the second VC-20-PRJ25. This is shown in Figure 4. Generally, the encoder signals on each board are synchronized with the oscillator on that board, and the decoder signals on each board are synchronized with the oscillator on the other board. This is done by connecting jumpers 1, 3 and 11 on each board. All other jumpers should be disconnected. The HD_SD control signal must be held high or left unconnected to disengage soft-decision decoding. Care must be taken that only one clock generator is connected to each of the clock signals TXCK, FMEN, RXCK and FMDE.

**SECTION
3**

Technical Specifications

Connector:	
Type	DIN 41612 Connector (male)

Physical:	
Description	100 mm (Single Euro-card [3U]) height (see Figure 6)

Analog Input:	
Type	single-ended
Impedance	600 ohm
Sensitivity	0 dBm0 = 0 dBm
Sinusoidal Overload	+3.17 dBm0
Nominal Level	-23 dBm0 (average speech level)
Dynamic Range	+/- 10 dB (relative to Nominal Level)
Noise Level	-72 dBm0

Analog Output:	
Type	single-ended
Impedance	low impedance output, capable of driving a 600 ohm load
Sensitivity	0 dBm0 = 0 dBm
Sinusoidal Overload	+3.17 dBm0
Nominal Level	-23 dBm0 (average speech level)
Dynamic Range	+/- 10 dB (relative to Nominal Level)
Noise Level	-72 dBm0
Bandwidth	20 – 3700 Hz.

Digital Interface:	
Type	TTL compatible

Power:	
	2 watts @ 5v digital, .2 watts @ +/- 5v analog

DIN41612 (96-pin Male) Connector Pin Description

Pin	ROW C		ROW B	ROW A	
	Function	Name		Function	Name
1	Digital Power	VCC	Reserved	Digital Power	VCC
2	Digital Power	VCC	Reserved	Digital Power	VCC
3	Ground	GND	Reserved	Ground	GND
4	Output	ITXD	Reserved	Output	QTXD
5	Reserved		Reserved	Input	TXCK
6	Input	FMEN	Reserved	Output	RUN
7	Reserved		Reserved	Output	RESX
8	Ground	GND	Reserved	Ground	GND
9	Input	IRXD	Reserved	Input	QRXD
10	Reserved		Reserved	Input	RXCK
11	Input	FMDE	Reserved	Reserved	
12	Reserved		Reserved	Reserved	
13	Ground	GND	Reserved	Ground	GND
14	Reserved		Reserved	Reserved	
15	Output	RESET	Reserved	Input	DINRS
16	Output	STATUS	Reserved	Reserved	
17	Output	ENSLNCE	Reserved	Reserved	
18	Input	IRXD1	Reserved	Input	QRXD1
19	Input	IRXD0	Reserved	Input	QRXD0
20	Ground	GND	Reserved	Ground	GND
21	Input	LOST	Reserved	Reserved	
22	Reserved		Reserved	Input	HD_SD
23	Reserved		Reserved	Reserved	
24	Input	FEC_OFF	Reserved	Reserved	
25	Input	DESLNCE	Reserved	Reserved	
26	Ground	GND	Reserved	Ground	GND
27	Analog Power	+5v analog	Reserved	Analog Power	+5v analog
28	Analog Power	-5v analog	Reserved	Analog Power	-5v analog
29	Output	VFRO	Reserved	Input	VFXI
30	Analog Ground	AGND	Reserved	Analog Ground	AGND
31	Ground	GND	Reserved	Ground	GND
32	Ground	GND	Reserved	Ground	GND

Note: Many Reserved signals are used to monitor the internal state of the VC-20-PRJ25. To ensure proper operation all reserved signals must be left unconnected.

VC-20-PRJ25 Connector Signals

Name	Type	Description
VCC	Power	Digital +5v +/- 5%
GND	Power	Digital Ground
+5v	Power	Analog +5v +/- 10%
-5v	Power	Analog -5v +/- 10%
GND Anlg	Power	Analog Ground
ITXD	Output	Transmit data I channel
QTXD	Output	Transmit data Q channel
TXCK	Input	Transmit data bit clock (3.6 kHz)
FMEN	Input	Encoder frame flag (Active High)
IRXD	Input	Receive data I channel (MSB)
IRXD1	Input	Receive data I channel
IRXD0	Input	Receive data I channel (LSB)
QRXD	Input	Receive data Q channel (MSB)
QRXD1	Input	Receive data Q channel
QRXD0	Input	Receive data Q channel (LSB)
RXCK	Input	Receive data bit clock (3.6 kHz)
FMDE	Input	Decoder frame flag (Active High)
LOST	Input	Lost speech frame detected flag (Active High)
RESET	Output	Voice codec reset flag (Active High)
STATUS	Output	Voice codec status flag (Active High)
ENSLNCE	Output	Encoder Silence Detected (Active Low) Disabled
DESLNCE	Input	Decoder silence control (Active Low)
VFRO	Output	Analog speech output signal
VRXI	Input	Analog speech input signal
RUN	Output	Run Status Signal (Active High)
RESX	Output	Internal Reset Status (Active Low)
DINRS	Input	Reset Signal (Active High)
HD_SD	Input	Enable Soft-decision Decoding (Active Low)
FEC_OFF	Input	Disable error correction and interleaving (Active Low)

VC-20-PRJ25 Connector Signal Descriptions

DESLNCE The DESLNCE flag signals the decoder that silence has been detected during the current frame. IF DESLNCE is active while FMDE is high, the decoder ignores the current frame of channel data and mutes the output VFRO.

DINRS DINRS is a VC-20-PRJ25 reset signal. An active high level on DINRS for a duration of at least 300ns will reset the VC-20-PRJ25. DINRS will generate RESX and RESET. The VC-20-PRJ25 will pull this signal to its inactive state (low) when it is not being driven by an external source (it may be left unconnected if not being used).

ENSLNCE The ENSLNCE flag is activated (low) by the encoder if it detects silence on VRXI. The ENSLNCE flag is deactivated (high) by the encoder two frames prior to the onset of voice activity. This is shown in figure 1. Note: silence detection is currently disabled, consequently ENSLNCE is never active.

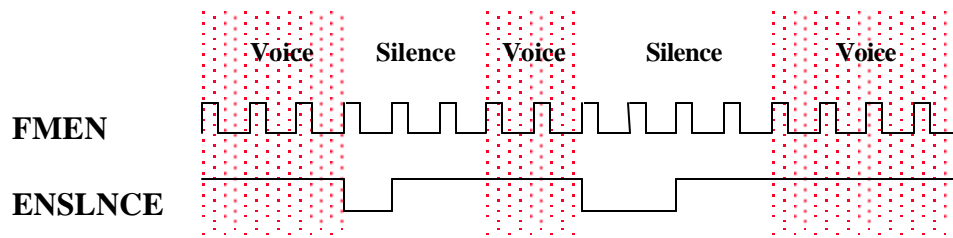

Figure 1: Voice/Silence Detection Timing

FEC_OFF The FEC_OFF signal can be pulled low to disable all error correction and interleaving. If FEC_OFF is pulled low, the prioritized bit vectors (88 bits) are output on ITXD and QTXD during the first 44 clock cycles of each 20 ms transmit frame, and ITXD and QTXD are set to zero during the remaining 28 clock cycles of each transmit frame. Also if FEC_OFF is pulled low, the prioritized bit vectors must be input on IRXD2-0 and QRXD2-0 during the first 44 clock cycles of each 20 ms receive frame, and IRXd2-0 and IRXd2-0 are ignored during the remaining 28 clock cycles of each receive frame. The FEC_OFF signal is sampled once every 20 ms when FMEN is high. If left unconnected, this signal is pulled internally to its inactive state (high).

FMDE This is the decoder frame flag which identifies the frame boundary of the channel input data. FMDE must be active for one clock period of RXCK every 20 ms.

FMEN This is the encoder frame flag which identifies the frame boundary of the channel output data. FMEN must be active for one clock period of TXCK every 20 ms.

GND, AGND	GND is the digital ground signal and AGND is the analog ground signal. These signals are connected on the VC-20-PRJ25.
HD_SD	The HD_SD signal must be set low to enable soft-decision decoding. This signal is sampled once every 20 ms data frame. If left unconnected, this signal is pulled internally to its inactive state (high).
IRXD, IRXD1, and IRXD0	IRXD, IRXD1, and IRXD0 are the in-phase data signals. These signals provide three bits of soft-decision information, with IRXD being the MSB and IRXD0 being the LSB. If the HD_SD control signal is low (soft-decision mode enabled), then all three data signals are read by the decoder. If HD_SD is high, then only IRXD (the MSB) is read by the decoder. These signals are each clocked into the VC-20-PRJ25 on the falling edge of RXCK at 3.6 kHz. These signals combined with the quadrature-phase data signals result in a total data rate of 7.2 kbps.
ITXD and QTXD	ITXD and QTXD are the in-phase and quadrature-phase voice data signals from the VC-20-PRJ25 encoder. These signals are each clocked at 3.6 kHz, giving a total data rate of 7.2 kbps.
LOST	The LOST flag is active if the current frame of channel data is invalid, in which case the decoder ignores the current frame of channel data and performs a frame repeat. This flag is only monitored during the first clock period of each frame.
RESET	The RESET signal is a software flag that indicates that the voice codec had been reset or that the encoder had lost synchronization. The VC-20-PRJ25 is reset under three conditions: during power-up, as a result of DINRS being asserted, or as a result of a Watch-Dog Timer reset. When the VC-20-PRJ25 successfully restarts from a reset or a loss of encoder synchronization, it will set the RESET flag high for one clock cycle of TXCK. This flag is synchronous with the rising edge of TXCK. RESET is a software flag; whereas, RESX is the hard-reset signal.
RESX	RESX is the reset status output signal. It is active when the VC-20-PRJ25 is being reset. The VC-20-PRJ25 is reset under three conditions: during power-up, as a result of DINRS being asserted, or as a result of a Watch-Dog Timer reset. This signal is an active low output. RESX is the VC-20-PRJ25's actual hard-reset signal; whereas, RESET is a software flag that is synchronous with TXCK.
RUN	RUN is a status signal that signifies that the VC-20-PRJ25 is encoding and decoding speech. This signal drives the green RUN LED. Each data frame is divided into an encoder window and a decoder window. The RUN signal is active within each respective window when the VC-20-PRJ25 is encoding or decoding speech (see figure 6). RUN is synchronous with TXCK.

- RXCK** This is the decoder symbol clock which controls the transfer of the channel data into the decoder. This signal must be 3.6 kHz +/- .05%. IRXD, IRXD1, IRXD0, QRXD, QRXD1, QRXD0, FMDE, LOST and DESLNCE are synchronous with the rising edge of this clock signal to within 500 ns.
- QRXD, QRXD1, and QRXD0** QRXD, QRXD1, and QRXD0 are the quadrature-phase data signals. These signals provide three bits of soft-decision information, with QRXD being the MSB and QRXD0 being the LSB. If the HD_SD control signal is low (soft-decision mode enabled), then all three data signals are read by the decoder. If HD_SD is high, then only IRXD (the MSB) is read by the decoder. These signals are each clocked into the VC-20-PRJ25 on the falling edge of RXCK at 3.6 kHz. These signals combined with the in-phase data signals result in a total data rate of 7.2 kbps.
- STATUS** The STATUS flag indicates the status of the voice codec. During normal operation, the voice codec sets this flag high for one clock cycle of TXCK every data frame. Absence of this signal during any data frame indicates an error condition. This flag is synchronous with the rising edge of TXCK.
- TXCK** This is the encoder data clock which controls the transfer of the channel data out of the encoder. This signal must be 3.6 kHz +/- .05%. ITXD, QTXD, FMEN, ENSLNCE, RESET, STATUS, and RUN are synchronous with the rising edge of this clock signal to within 500 ns.
- VFRO** VFRO is the analog speech output produced by passing the decoder output through a 16 bit linear codec. VFRO has an analog bandwidth of 100 Hz. - 3600 Hz., and it is constrained to be within +/- 1.5 volts.
- VRXI** VFXI is the analog speech input which is filtered with a 100 Hz. - 3600 Hz. bandpass filter and then input to the encoder via a 16 bit linear codec. In order to avoid clipping VRXI must not exceed +/- 1.5 volts.

VC-20-PRJ25 on-board jumpers Connector Signals

Jumper	Signal
1	Connects on-board 3.6 kHz data clock to TXCK
2	Connects on-board 3.6 kHz data clock to RXCK
3	Connects on-board 20 ms frame clock to FMEN
4	Connects on-board 20 ms frame clock to FMDE
5	Connects ITXD to IRXD0 (LSB)
6	Connects ITXD to IRXD1
7	Connects ITXD to IRXD (MSB)
8	Connects QTXD to QRXD0 (LSB)
9	Connects QTXD to QRXD1
10	Connects QTXD to QRXD (MSB)
11	Deactivates LOST signal
12	Deactivates DESLNCE signal
13	reserved (leave unconnected)
14	reserved (leave unconnected)

SECTION
4

Technical Drawings

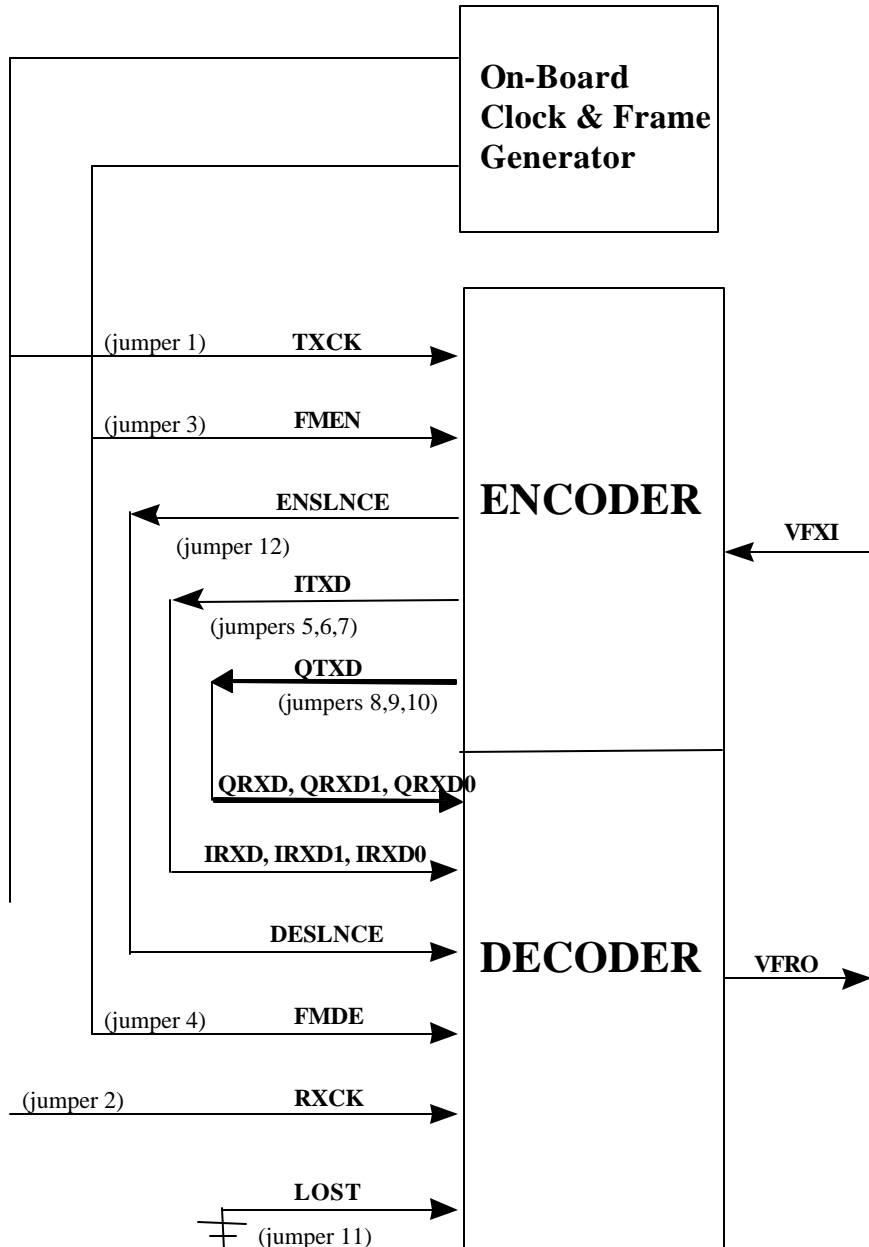

Figure 2: Vocoder Connections in Loop back Mode

Note: Not meant to represent an “off-the-shelf” modem

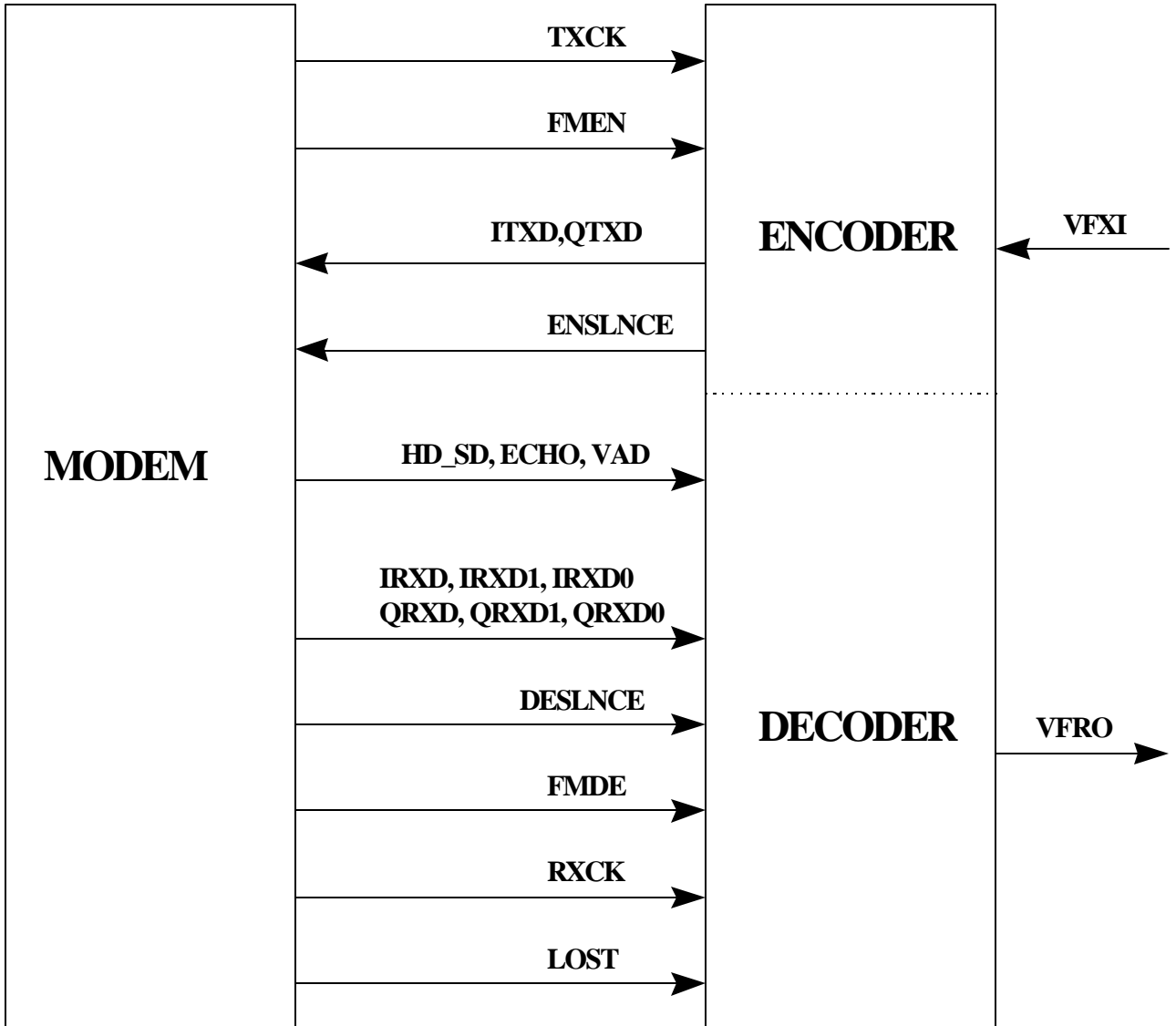

Figure 3: Connections between Vocoder and a Modem

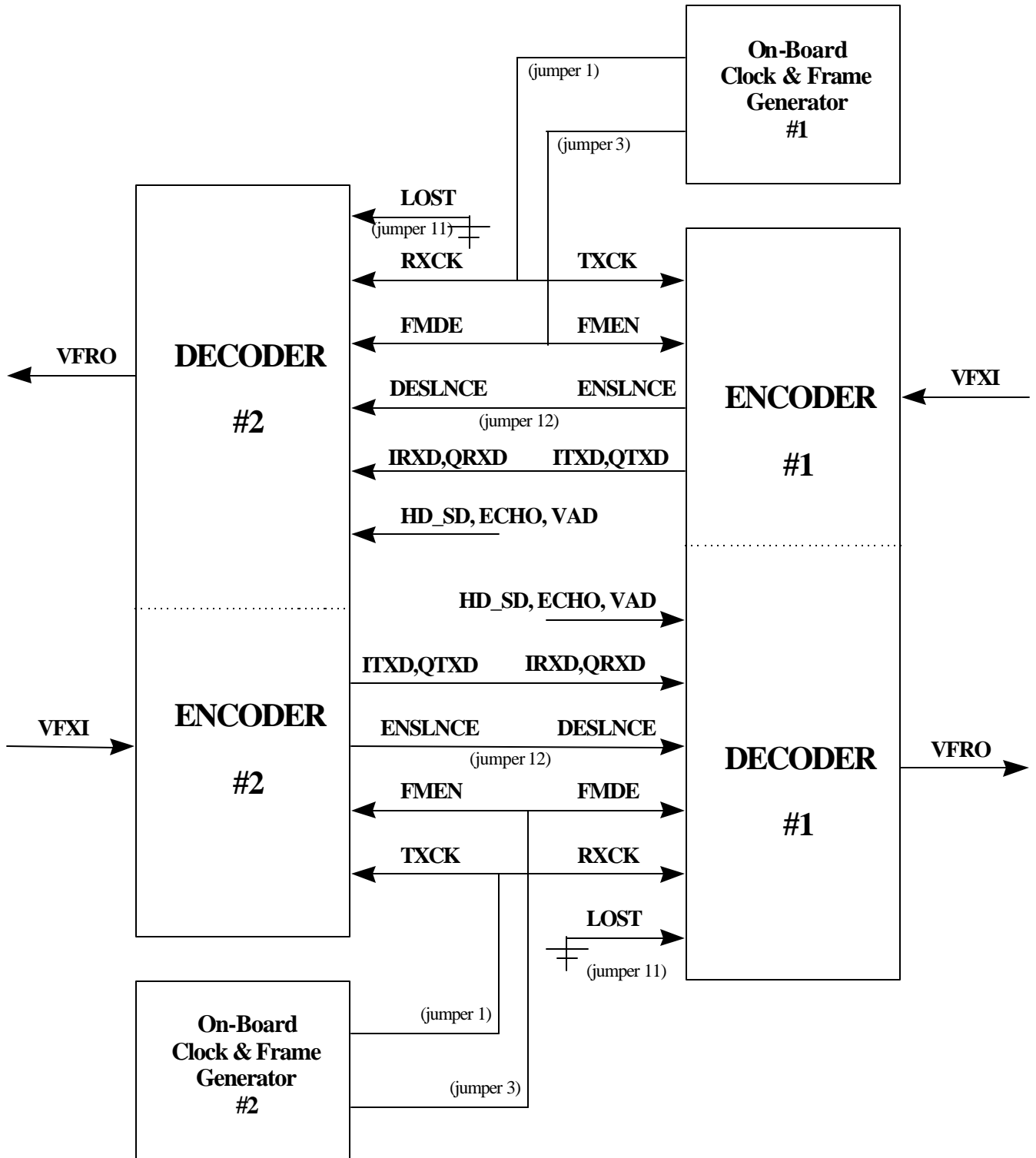

Figure 4: Dual Vocoder Connections

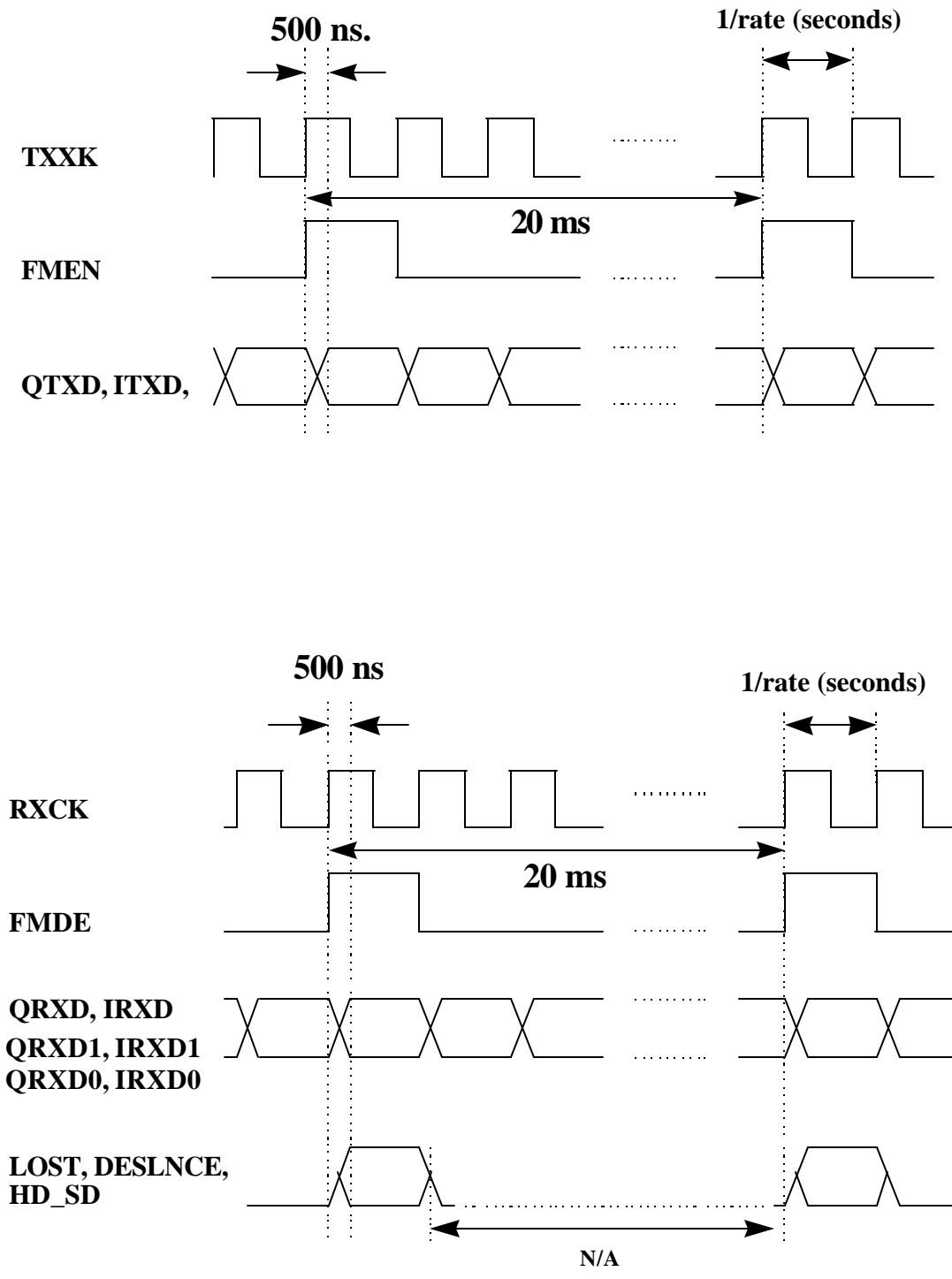

Figure 5: Channel Interface Timing Relationships

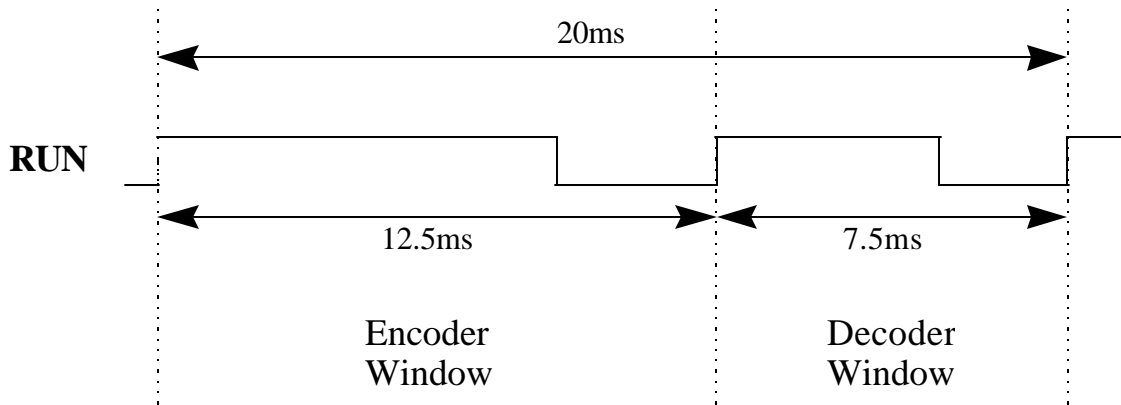
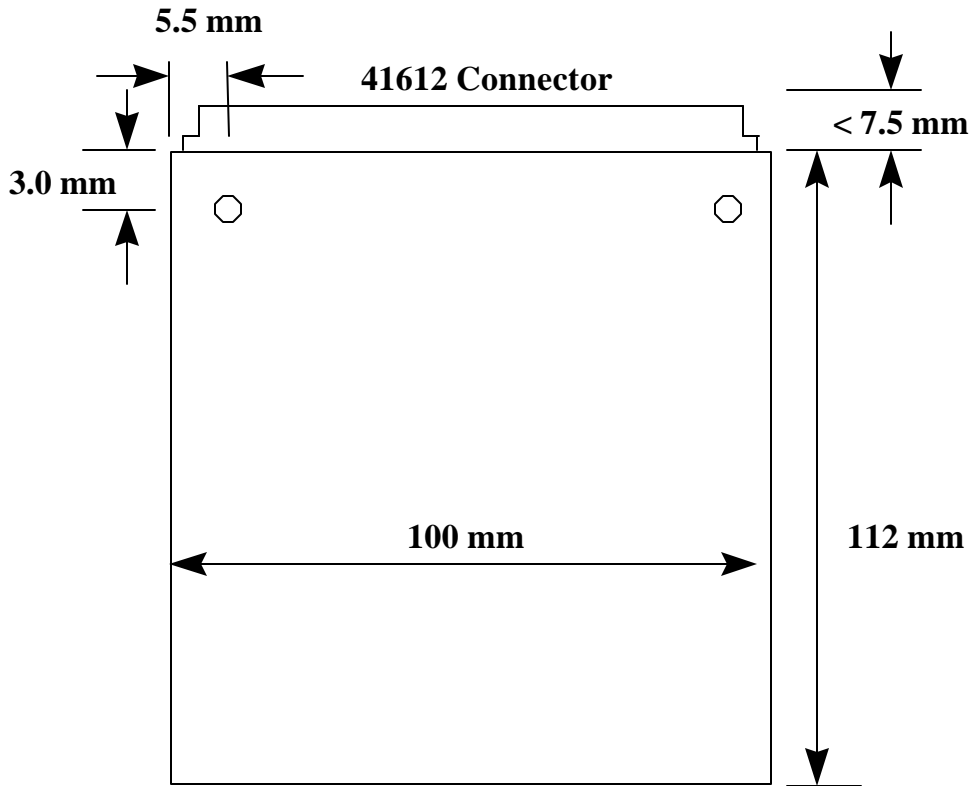
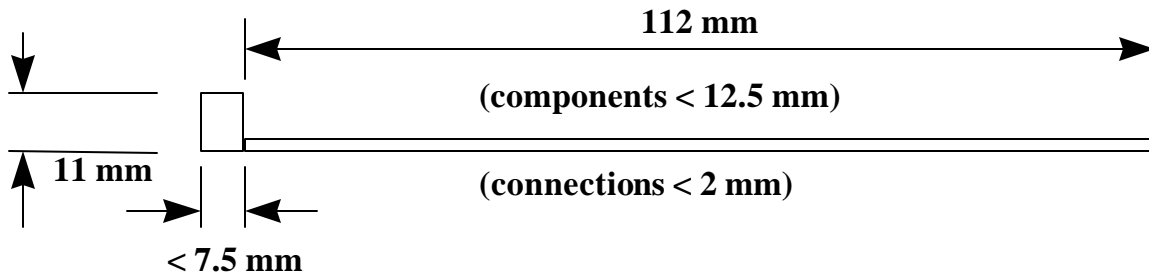

Figure 6: RUN Signal Timing



(bottom view)



(side view)

Figure 7: Vocoder Physical Dimensions

SECTION 5

DVSI Support Services

Technical Support

If you have any problems with the VC-20-PRJ25 IMBE™ Vocoder Board or have questions about its operation, please contact:

Digital Voice Systems, Inc.
234 Littleton Road
Westford, MA 01886 USA

Phone: (978) 392-0002

Fax: (978) 392-8866

email: info@dvsinc.com

web: www.dvsinc.com

NOTES