

VC-55™-PR
Voice Codec Board
User's Manual
Version 1.1
February 2009

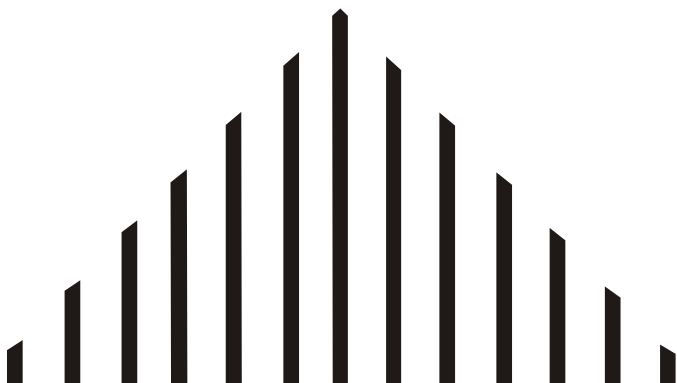

VC-55™-PR Voice Codec Board
User's Manual
Version 1.1, February 2009

©Copyright, 2005
Digital Voice Systems, Inc
234 Littleton Road
Westford, MA 01886

This document may not, in whole or in part be copied, photocopied, reproduced, translated, or reduced to any electronic medium or machine readable form without prior consent in writing from Digital Voice Systems, Incorporated.

Every effort has been made to ensure the accuracy of this manual. However, Digital Voice Systems, Inc. makes no warranties with respect to the documentation and disclaims any implied warranties of merchantability and fitness for a particular purpose. Digital Voice Systems, Inc. shall not be liable for any errors or for incidental or consequential damages in connection with the furnishing, performance, or use of this manual or the examples herein. The information in this document is subject to change without notice.

Trademarks

VC-55™-PR Voice Codec Board, AMBE+2™ and AMBE+™ are trademarks of Digital Voice Systems, Inc. AMBE® is a registered trademark of Digital Voice Systems, Inc. Other product names mentioned may be trademarks or registered trademarks of their respective companies and are the sole property of their respective manufacturers.

Windows 200/XP/Server, Windows 98/Me are trademarks of their respective owners.

All Rights Reserved
Data subject to change

VC-55™- PR Voice Codec Board END USER License Agreement

1.0 Preliminary Statements and Definitions

1.1 "Voice Codec Board" shall mean the hardware, software and associated documentation referred to in the invoice or shipping papers accompanying this agreement for which END USER has requested a license, and any derivative works thereof, including modifications, enhancements and extensions made by or for Digital Voice Systems, Inc. (DVS) and including circuit diagrams, timing diagrams, programmable logic software, logic diagrams, layouts, operating instructions and user manuals.

"AMBE™ Software" shall mean the speech coding software and/or firmware provided as part of the Voice Codec Board. This software is contained in the Read Only Memories (ROMs, EPROMs, EEPROMs, etc...) which are included as part of the Voice Codec Board. This software includes any derivative works which have as their source the software contained in the Read Only Memories, and it includes the software contained in any future Read Only Memories which DVS may provide END USER for use in the Voice Codec.

1.3 "Designated Site" shall mean the location of the Voice Codec Board.

1.4 "Proprietary Information" shall mean the information which DVS desires to protect against unrestricted disclosure or competitive use and which is designated as such in writing by DVS or is disclosed orally and within thirty (30) days thereafter is reduced to tangible form pursuant to this License.

DVS represents that it owns certain "Proprietary Rights" in the Technology and in the AMBE® and AMBE+2™ Voice Compression Software, including patent rights in the Technology, and patent rights, copyrights, and trade secrets in the AMBE® and AMBE+2™ Voice Compression Software.

2.0 License Granted

2.1 Subject to the conditions herein and upon initial use of the AMBE™ and AMBE+2™ Software within the VC-55™-PR Voice Codec Board, DVS hereby grants to END USER a non-exclusive, limited license to use the AMBE® and AMBE+™ Voice Compression Software internal to the VC-55™-PR Voice Codec Board. Title to the AMBE® Voice Compression Software remains with DVS. No license is granted for use of the AMBE® AMBE+™ Voice Compression Software on other than the VC-55™-PR Voice Codec Board. No license, right or interest in any trademark, trade name or service mark of DVS is granted under this Agreement.

2.2 END USER shall not copy, extract, de-compile, reverse engineer or disassemble the AMBE® and AMBE+™ Voice Compression Software contained in the VC-55™-PR Voice Codec Board.

2.3 Transfer of License

(a) END USER may transfer the VC-55™-PR Voice Codec Board with the AMBE® and AMBE+™ Software and all rights under this agreement to a third party together with a copy of this Agreement provided that END USER provides DVS with a written notification of the transfer and provided that the third party agrees in writing to accept all the terms and conditions of this agreement. Upon any such transfer, END USER's rights under this Agreement shall terminate pursuant to Section 3.0.

(b) END USER may relocate the VC-55™-PR Voice Codec Board, and the subsequent location shall then be considered the Designated Site.

(c) Except as provided in this Section 2.2, this Agreement, the AMBE® and AMBE+™ Software and any other information provided by DVS to END USER and any licenses and rights granted hereunder, may not be sold, leased, assigned, sublicensed or otherwise transferred, in whole or in part, by END USER.

2.4 END USER shall not de-compile, reverse engineer or disassemble the VC-55™-PR Voice Codec Board, AMBE® and AMBE+™ Software.

3.0 Term and Termination

3.1 This Agreement is effective upon initial use of the AMBE® and AMBE+™ Software on the VC-55™-PR Voice Codec Board and shall remain in effect until terminated in accordance with this agreement.

3.2 This Agreement shall terminate automatically without notice from DVS if END USER fails to comply with any of the material terms and conditions herein. END USER may terminate this Agreement at any time upon written notice to DVS certifying that END USER has complied with the provisions of Section 3.3.

3.3 Upon termination of this Agreement for any reason, END USER shall: (i) have no further rights to the VC-55™-PR Voice Codec Board and AMBE® and AMBE+™ Software; (ii) discontinue all use of the VC-55™-PR Voice Codec Board and AMBE® and AMBE+™ Software; and (iii) destroy or, at DVS's option, return the VC-55™-PR Voice Codec Board and AMBE® and AMBE+™ Software.

4.0 Payments

4.1 In consideration of the hardware, software, and associated materials provided as part of the VC-55™-PR Voice Codec Board and AMBE® and AMBE+™ Software, and in consideration of the license and rights in the AMBE® and AMBE+™ Software granted by DVS, and in consideration of DVS's performance of its obligations hereunder, END USER agrees to pay to DVS the fee specified in DVS's invoice.

5.0 Proprietary Notices

5.1 END USER shall not remove any copyright or proprietary notice on the on the VC-55™-PR Voice Codec Board and AMBE® and AMBE+™ Voice Compression Software.

6.0 Proprietary Information

6.1 The parties agree that the VC-55™-PR Voice Codec Board and AMBE® and AMBE+™ Software, Voice Compression Software shall be considered Proprietary Information.

6.2 Except as otherwise provided in this Agreement, END USER shall not use, disclose, make, or have made any copies of the Proprietary Information, in whole or in part, without the prior written consent of DVS.

6.3 END USER shall make reasonable efforts to notify and inform its employees having access to the Proprietary Information of END USER's limitations, duties and obligations regarding nondisclosure and copying of the VC-55™-PR Voice

Codec Board and AMBE® and AMBE+™ Software,. Proprietary Information shall be used only by employees of END USER and only at the Designated Site, except as provided under this agreement.

6.4 END USER shall have no obligations for disclosure or use of Proprietary Information which: (i) is already known to END USER, at time of disclosure by DVSI; (ii) is or becomes publicly known through publication, inspection of product or otherwise through no wrongful act of END USER; (iii) is received from a third party without restriction and without breach of this Agreement; (iv) is independently developed by END USER; (v) is disclosed to a third party by or on behalf of DVSI without restriction; or (vi) is approved for release or use by written authorization of DVSI.

6.5 Notwithstanding any termination pursuant to Section 3.0, the obligations set forth in this Section 6.0 shall survive termination of this Agreement.

7.0 Limited Warranty

7.1 DVSI warrants the VC-55™-PR Voice Codec Board and AMBE® and AMBE+™ Software, to be free from defects in materials and workmanship under normal use for a period of ninety (90) days from the date of delivery. DVSI further warrants that the VC-55™-PR Voice Codec Board and AMBE® and AMBE+™ Software, operate in accordance with the written specifications delivered to END USER with the VC-55™-PR Voice Codec Board,.

7.2 Except as stated in Section 7.1, the VC-55™-PR Voice Codec Board and AMBE® and AMBE+™ Software, are provided "as is" without warranty of any kind. DVSI does not warrant, guarantee or make any representations regarding the use, or the results of the use, of the VC-55™-PR Voice Codec Board and AMBE® and AMBE+™ Software, with respect to its correctness, accuracy, reliability, correctness or otherwise. The entire risk as to the results and performance of the VC-55™-PR Voice Codec Board and AMBE® and AMBE+™ Software, is assumed by the END USER. After expiration of the warranty period, END USER, and not DVSI or its employees, assumes the entire cost of any servicing, repair or correction of the VC-55™-PR Voice Codec Board and AMBE® and AMBE+™ Software,.

7.3 DVSI warrants that it has the right to enter into this Agreement and to grant a license to use the VC-55™-PR Voice Codec Board and AMBE® and AMBE+™ Software, to END USER.

7.4 Except as specifically set forth in this Section 7.0, DVSI makes no express or implied warranties including, without limitation, the warranties of merchantability or fitness for a particular purpose or arising from a course of dealing, usage or trade practice, with respect to the VC-55™-PR Voice Codec Board and AMBE® and AMBE+™ Software, . Some states do not allow the exclusion of implied warranties, so the above exclusion may not apply to END USER. No oral or written information or advice given by DVSI or its employees shall create a warranty or in any way increase the scope of this warranty, and END USER may not rely on any such information or advice. The limited warranties under this section 7.0 give END USER specific legal rights, and END USER may have other rights which vary from state to state.

8.0 Limitation of Liability

8.1 In no event shall DVSI be liable for any special, incidental, indirect or consequential damages resulting from the use or performance of the VC-55™-PR Voice Codec Board and AMBE® and AMBE+™ Software, whether based on an action in contract, tort (including negligence) or otherwise (including, without limitation, damages for loss of business profits, business interruption, and loss of business information), even if DVSI or any DVSI representative has been advised of the possibility of such damages.

8.2 Because some states do not allow the exclusion or limitation of liability for consequential or incidental damages, the above limitations may not apply to END USER.

8.3 DVSI's maximum liability for damages arising under this Agreement shall be limited to 20% (twenty percent) of the fees paid by END USER for the particular VC-55™-PR Voice Codec Board which caused the damages or that is the subject matter of, or is directly related to, the cause of action.

9.0 Taxes

9.1 All payments required under Section 4.0 or otherwise under this Agreement are exclusive of taxes and END USER agrees to bear and be responsible for the payment of all such taxes (except for taxes based upon DVSI's income) including, but not limited to, all sales, use, rental receipt, personal property or other taxes which may be levied or assessed in connection with this Agreement.

10.0 Export

10.1 United States export laws and regulations prohibit the exportation of certain products or technical data received from DVSI under this Agreement to certain countries except under a special validated license. As of May 20, 1996 the restricted countries are: Libya, Cuba, North Korea, Iraq, Serbia, Montenegro, and Iran. The END USER hereby gives its assurance to DVSI that it will not knowingly, unless prior authorization is obtained from the appropriate U.S. export authority, export or re-export, directly or indirectly to any of the restricted countries any products or technical data received from DVSI under this Agreement in violation of said United States Export Laws and Regulations. DVSI neither represents that a license is not required nor that, if required, it will be issued by the U.S. Department of Commerce. Licensee shall assume complete and sole responsibility for obtaining any licenses required for export purposes.

11.0 Governing Law

11.1 This Agreement is made under and shall be governed by and construed in accordance with the laws of the Commonwealth of Massachusetts, except that body of law governing conflicts of law. If any provision of this Agreement shall be held unenforceable by a court of competent jurisdiction, that provision shall be enforced to the maximum extent permissible, and the remaining provisions of this Agreement shall remain in full force and effect.

12.0 Notices

Any notices to DVSI which may be given hereunder shall be sent in writing to: Digital Voice Systems Inc., 234 Littleton Road, Westford, MA, 01886 USA

Special Handling Instructions

To avoid damage from the accumulation of a static charge, industry standard electrostatic discharge precautions and procedures must be employed during handling and installation the VC-55™-PR Vocoder Board.

1. Read Instructions and Users Manual – All of the safe handling and operating instructions should be read before integration of the VC-55™- PR Vocoder Board begins. Failure to exercise reasonable care and to follow all instructions and heed all warnings may result in injury to property or to individuals.
2. Retain Instructions - The handling and operating instructions should be retained for future reference.
3. Follow Instructions - All operating and use instructions should be followed.

Storage

To insure maximum shelf life in long term storage, VC-55-PR Vocoder board should be kept in an a static shield, moisture controlled package at <40°C and <90% Relative Humidity

Installation

Ventilation - The VC-55™- PR Vocoder Board unit should be situated so that its location or position does not interfere with proper ventilation and air circulation around the board.

Heat - The VC-55™- PR Vocoder Board unit should be situated away from devices that could act as a heat source such as an amplifier.

Power Sources - The VC-55™- PR Vocoder Board should be connected to a power source only of the type described in this Users Manual.

Table of Contents

Section 1 INTRODUCTION	1
GENERAL INFORMATION	1
Section 2 INSTALLATION	3
OPERATION OVERVIEW	3
VC-55™- PR VOCODER BOARD CONNECTIONS	3
<i>Connecting DC Power</i>	5
<i>Analog Audio I/O</i>	6
<i>Handset</i>	6
<i>USB Port</i>	6
<i>Connecting two Boards together via UART</i>	6
<i>Connecting the UART Serial Connection to another device</i>	7
Section 3 SETUP & CONTROL.....	8
OVERVIEW	8
<i>Installing USB driver INF files On Windows 2000/XP/Server 2003</i>	8
<i>Installing USB driver INF files on Windows 98/Me:</i>	9
<i>Running the VC-55™ Vocoder Board Program vc55param.exe</i>	10
<i>Running the Program</i>	12
<i>VC-55™ -PR Vocoder Board Status</i>	13
Section 4 CHANNEL INTERFACE.....	15
VOCODER BOARD CHANNEL BASIC OPERATION	15
DATA STRUCTURE	15
Section 5 SPECIFICATIONS	17
INTRODUCTION	17
BOARD CONNECTIONS	17
<i>Channel Connection</i>	17
<i>Audio I/O Connections</i>	17
<i>USB Connection</i>	18
ELECTRICAL INPUT	18
MECHANICAL.....	19
Section 6 SUPPORT	20
DVSI TECHNICAL SUPPORT	20

List of Tables

TABLE 1 OPTIONAL ACCESSORY KIT	2
TABLE 2 TOP PANEL CONNECTORS	5
TABLE 3 UART SERIAL PORT SETTINGS.....	7
TABLE 4 VC55PARAM VARIABLES	12
TABLE 5 VC55PARAM OUTPUT TO SCREEN.....	13
TABLE 6 PACKET STRUCTURE.....	15
TABLE 7 VOCODER RATE ELEMENTS	16
TABLE 8 RATES DESCRIPTION	16
TABLE 9 RS-232 SERIAL PORT PIN OUT.....	17
TABLE 10 RS-232 SERIAL PORT PIN OUT.....	18

List of Figures

FIGURE 1 BLOCK DIAGRAM	4
FIGURE 2 VC-55™- PR VOCODER BOARD TOP.....	5
FIGURE 3 POWER INPUT CONNECTION.....	5
FIGURE 4 CONNECTING TWO VC-55™-PR VOCODER BOARD'S TOGETHER.....	6
FIGURE 5	14

SECTION 1

Introduction



General Information

The Digital Voice Systems, Inc. (DVSI) VC-55™- PR Vocoder Board is a single channel full-duplex real-time voice processing board. The VC-55™-PR Vocoder Board implements DVSI's proprietary Advanced Multi-Band Excitation™ voice coding algorithm software.

The VC-55™- PR Vocoder Board is a full-duplex real-time voice compression solution that is ideally suited for OEM systems in a variety of applications including digital mobile radio communication systems, wireless telephony and voice monitoring / recording systems compressed-voice storage ideal for or non-real-time testing and evaluation of DVSI vocoder performance applications. With its single channel capability and compact design the PC board is engineered for easy integration into a new or existing digital communication systems.

VC-55™- PR Features	
✓	DVSI AMBE™ +2 Voice Coder provides Superior Voice Quality
✓	Robust to Bit Errors & Background Noise
✓	Dual Data Rates - 7.2 kbps and 3.6 kbps
✓	Real-Time Full-Duplex Communication
✓	High performance audio using 16-bit linear stereo codec.
✓	Compact Design
✓	Low Power Consumption
✓	Low Cost
✓	USB port provides system setup and control.
✓	The embedded system software is field upgradeable.
✓	Windows 98 Win2K and WinXP Compatible

The VC-55™- PR hardware incorporates DVSI's patented voice compression vocoder software geared toward the next generation of APCO Project 25 (P25) digital mobile radio communication systems. Providing the best in voice compression performance, the VC-55™- PR integrates an enhanced dual rate (7200/3600 bps) APCO P25 implementation.

The enhanced full-rate 4400 bps vocoder with 2800 bps of integrated Forward Error Correction (FEC) significantly improves voice performance and provides a number of other vocoder advancements while remaining fully interoperable with the existing APCO Project 25 vocoder standard (TIA-102BABA). The enhanced half-rate APCO P25 vocoder operates at 2450 bps with 1150 bps of FEC to maximize system resources and improve channel efficiency by doubling the number of public safety communication channels. This low-bit-rate vocoder is fully interoperable with the new half-rate vocoder proposed by DVSI for APCO Project 25 Phase II.

Both vocoders are based on DVSI's Multi-Band Excitation (MBE) technology that codes speech using a set of MBE model parameters for each frame of speech. These enhanced vocoders advance this speech coding method even further. By incorporating DVSI's latest quantization, Forward error Correction (FEC) and Noise suppression technology they maximize communication system resources and improve user comprehension (even in channel conditions degraded by significant bit errors or acoustic background noise). In recent MOS testing, DVSI's enhanced low bit rate vocoders have been proven to consistently score significantly above the competition by delivering the highest quality voice

under all tested conditions. These superior performance characteristics make the enhanced vocoders ideal for use in any digital communication application where bandwidth is at a premium and high quality voice is imperative.

The VC-55™- PR is an economical hardware solution for customers who want to gain access to the APCO Project 25 (P25) land mobile radio vocoder technology. By integrating the enhance vocoder software into a hardware platform DVSI can offer a package without the licensing fees or royalties associated with software only solutions. With off-the-shelf availability, the VC-55™- PR provides cost effective voice compression vehicle that can reduce the time and up-front engineering expenses associated with new product development.

VC-55™ Vocoder Board Applications	
✓	Digital Mobile Radio
✓	Cellular Telephony and PCS
✓	Satellite Communications
✓	Secure Communications
✓	Voice delivery systems
✓	Voice Multiplexing
✓	Voice Mail
✓	Voice recording and logging

To begin using the board for evaluation and testing of the DVSI vocoders quick and easy there is a accessory kit available the contains the basic components the are need to operate the board. Also, sample files are included with the board including a PCM, encoded file and decoded file

Optional Accessories Kit	
<i>Item</i>	<i>Description</i>
Power Adapter	AC to 5 Volt DC
Handset with Cord	Connects to RJ11 Connector

Table 1 Optional Accessory Kit

Vocoder Board is a full-duplex real-time voice compression solution that is perfect for low risk prototype development and small volume manufacturing. The single board design also reduces system integration time.

The VC-55™ Vocoder Board uses DVSI's own interface described in section 4. This allows users to develop their own application controls and user interfaces for an endless array of customized applications.

Before using the VC-55™- PR, read through this user's manual in its entirety, paying careful attention to the safety instructions beginning on page ii.

SECTION 2

Installation



Operation Overview

The VC-55™-PR vocoder board uses an on-board A/D converter to digitize the analog speech input. The digitized speech is then encoded by the DVSI voice compression algorithm into a 7200 bps or 3600 bps serial data bit stream which includes FEC. The digital data is then available for output to a modem or similar device.

Simultaneously, the VC-55™-PR vocoder board receives a data bit stream from the modem or similar device. The data received is processed by the decoder, reconstructed into digitized speech and then converted into an analog signal using an on-board D/A converter. The encoder and decoder are fully asynchronous.

VC-55™- PR Vocoder Board Connections

The VC-55™- PR Vocoder Board hosts a variety of inputs and outputs that provide flexibility in system integration. The VC-55™- PR Vocoder Board is designed to communicate over a serial interface with the ability to be set-up and controlled through a USB interface using a PC.

The VC-55™-PR is designed with ease of use and system integration in mind. The vocoder board is manufactured with components mounted on both sides to achieve a small form factor. This unique design increases the number of ways the board can be integrated into an OEM digital communication system.

Block Diagram

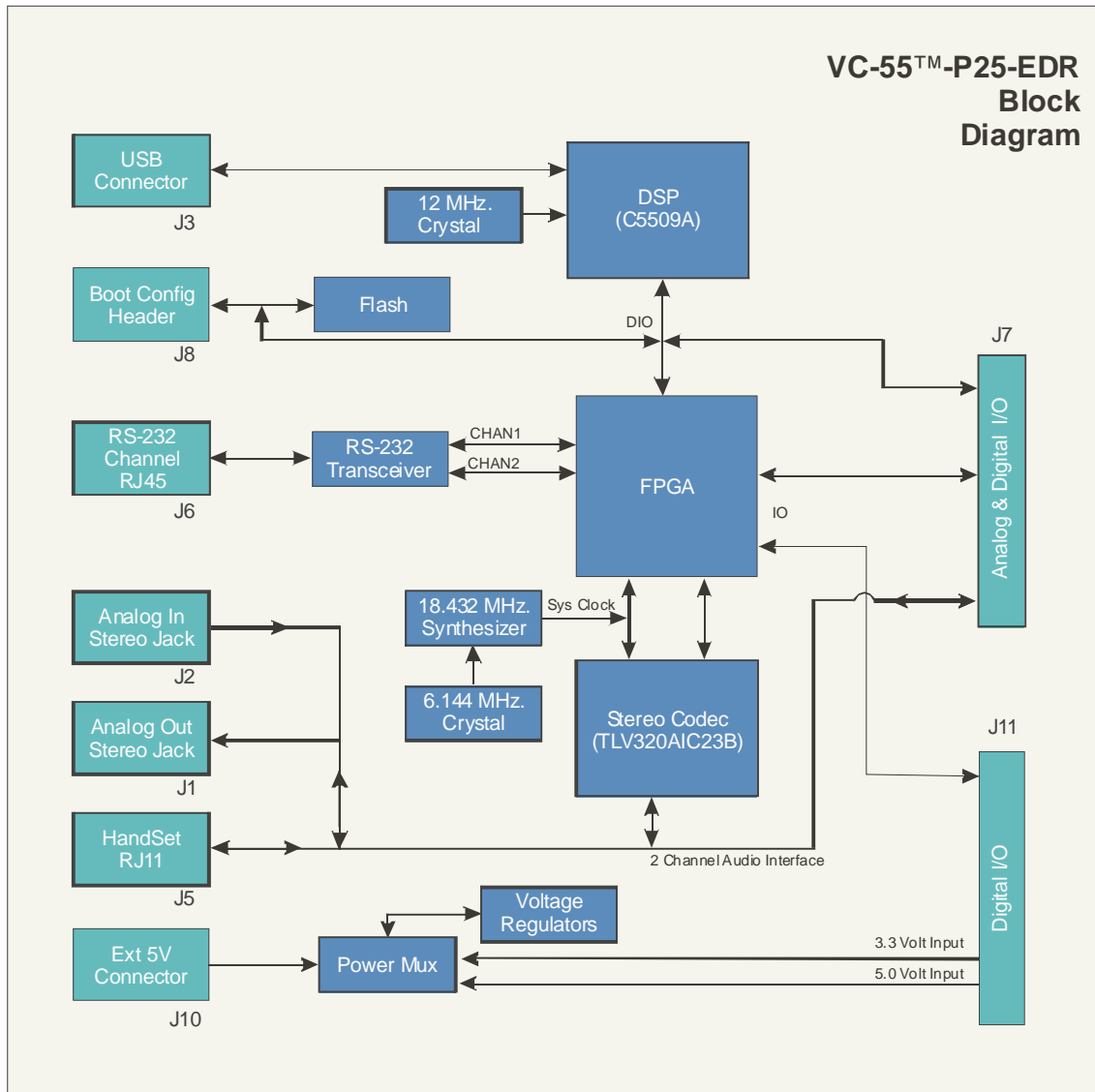

Figure 1 Block Diagram

To meet a wide variety of communication system requirements the VC-55™- PR Vocoder Board contains two analog interfaces for real-time speech input and output and an USB interface for set-up and control from a PC. The VC-55™-PR Vocoder Board analog interface includes a 4-wire and a handset for input and output of uncompressed speech.

For the channel connection, the VC-55™ Vocoder Board provides an asynchronous RS-232 interface for connecting directly to a serial device or another VC-55™ Vocoder Board. When two VC-55™-PR Vocoder boards are connected together to communicate, each converts the input analog speech into digital speech samples, encodes the speech using the selected vocoder rate and then sends the compressed bit stream out as serial data packets over the RS-232 interface. Simultaneously, the compressed bit stream from the other VC-55™-PR are read in from the RS-232 interface and decoded back in to digital speech samples. The decoded samples are converted back into analog speech via the AIC-23B codec whose output is sent to both the handset and line-level output connections.

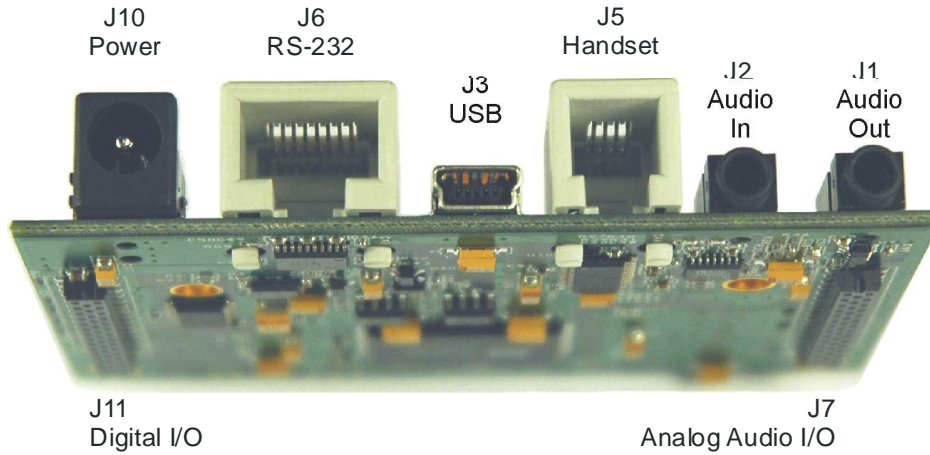

Figure 2 VC-55™- PR Vocoder Board Top

Board Top Connections			
Item	Name	Connector Type	Description
J6	Serial Port	RJ-45	Channel Data
J3	USB*	Type Mini-B Receptacle	Control / Program / File IO
J2	Analog Line In	3.5mm Audio Jack	Audio from Line In
J1	Analog Line Out	3.5mm Audio Jack	Audio out to Spkrs / amp
J5	Handset	RJ-11	Full Duplex Communication
J10	DC Line In	Power Receptacle	5 Volts DC

Table 2 Top Panel Connectors

Connecting DC Power

The user must supply the VC-55™-PR Vocoder Board with a 5 V digital power supply. There are no user settings. Just plug in the 5V DC 250ma power source into the DC power receptacle on the board receptacle (See Table 2 Top Panel Connectors item 9). DVSI offers an optional accessories kit that contains a AC to DC converter for the VC-55™-PR Vocoder Board.



Figure 3 Power Input Connection

The OEM version of the board has the Power connections located on J11. The board will operate with either 3.3 V DC or 5.0 V DC as shown in the following table:

Bottom Connector J11				
5.0 V DC Power		or	3.3 V DC Power	
Pins	Name		Pins	Name
6,8	5.0 V DC Input		2,4	3.3 V DC Input
1, 3, 5, 7, 13, 14, 21, 22, 29, 30	Digital Ground	1, 3, 5, 7, 13, 14, 21, 22, 29, 30	Digital Ground	

Note: Do not apply both the 5V DC and 3.3 V DC power at the same time.

Analog Audio I/O

A typical analog audio input connection for the VC-55™- PR Vocoder Board would be to connect the audio Line out output of an audio component, a Digital Tape, player or even a PC sound card output to the Analog Input jack (audio cables not included). The VC-55™- PR Vocoder Board outputs the analog signal on the output RCA jack that may be connected to an amplifier or Audio In jack on a PC sound card. The unit always outputs the audio to both the 4-Wire and Handset output regardless of which voice source is selected.

Handset

If a handset is used instead of the 4 wire interface, use the telephone handset included with the board's accessory kit (to assure the correct microphone levels) to connect to the RJ11 handset connector. The handset cord is less than a foot long to help reduce noise from being introduced into the voice signal. The VC-55™- PR Vocoder Board always outputs the audio to both the 4-Wire and Handset output regardless of which voice source is selected.

USB Port

The USB 2 connection on the VC-55™- PR Vocoder Board unit provides system boot setup, mode of operation and control of the audio I/O via PC. The USB interface allows the operation software to be field upgradeable.

The VC-55™- PR Vocoder Board comes with easy to install drivers that work under WinXP Win2000 and Win98. Installation of the drivers is described in the following Section. To connect the VC-55™ Vocoder Board to a PC USB port a USB "Type A to Mini-B" cable is required (included in the optional accessories kit).

Connecting two Boards together via UART

Establishing a real-time, full-duplex communication link between two boards is as easy as connecting a cable directly between the two units. The VC-55™- PR Vocoder Board implements an asynchronous RS-232 serial interface for channel data using a protocol designed by DVSI. Analog voice from one VC-55™- PR Vocoder Board is encoded and sent through the RS-232 channel interface to another VC-55™- PR Vocoder Board. Incoming channel packets from RS-232 are decoded and played out on the handset of the second VC-55™- PR Vocoder Board. Once the link is established voice communication for each board can be made through either the handset or stereo phono plug line input.

Cable pinout for UART Asynchronous Serial Port			
RJ45 Connector End 1		RJ45 Connector End 2	
Pin Number	Signal Name	Signal Name	Pin Number
1	Not Connected	Not Connected	3
2, 5, 6, 8	Ground	Ground	2, 5, 6, 8
7	Tx Channel out	Rx Channel In	4
3	Not Connected	Not Connected	1
4	Rx Channel In	Tx Channel out	7

Figure 4 Connecting two VC-55™-PR Vocoder Board's together

Connecting the UART Serial Connection to another device

Serial Port Settings	
Bits per second:	115,200
Data bits:	8
Parity:	None
Stop bits:	1
Flow control:	None

Table 3 UART Serial Port Settings

SECTION 3

Setup & Control



Overview

The VC-55™-PR vocoder board can be set up and running in a matter of minutes. With a second VC-55™-PR board you can use the UART connection to create a real-time full-duplex serial communication link between two devices. Each board is shipped with the software loaded and ready to go. When power is applied to the board the VC-55™-PR boots from the onboard flash and is up and running in seconds. Users can write to the flash from the USB interface allowing customization of the VC-55™-PR power up parameters. The board is equipped LEDs indicators that allow for quick and easy determination of board's operational status.

The VC-55™ Vocoder Board can encode data from either the handset or 3.5mm stereo jack (Line In) connections. Which ever source is used the analog speech signal is first digitized by the on-board A-to-D converter and then processed by the encoder and converted into a Formatted Data bit stream This compressed bit stream which contains the respective data bit stream (the data rate depends on the software setting) will be output to the RS-232 interface.

The VC-55™ Vocoder Board Decodes the encoded data received from the RS-232 connection and then plays it back through the 16 bit D-to-A converter to the handset or output jack. The encoder and decoder are fully asynchronous.

Installing USB driver INF files On Windows 2000/XP/Server 2003

To run the board in USB file mode it is necessary to install the appropriate drivers and connect to the USB interface. To install the drivers

- ✓ Step 1 Insert the CD into your PC.
- ✓ Step 2 Create a folder on your C:\ named VC55
- ✓ Step 3 Copy the entire contents of the CD this folder
- ✓ Step 4 Open a command prompt window
- ✓ Step 5 Go to the C:\vc55\vc55usbdrv folder (from the command line) type

```
cd C:\vc55\vc55usbdrv
```

- ✓ Step 6 Be sure that the following files are in this folder (to print to screen the files in this folder) type

```
dir
```

the response will be

```
c5509a.inf  
vc55r10.inf  
wd_utils.dll  
wdreg.exe  
wdreg16.exe  
windrvr6.inf  
windrvr6.sys
```

- ✓ Step 7 Copy the **wd_utils.dll** file to your C:\windows\system32 folder type

```
copy wd_utils.dll C:\windows\system32
```

- ✓ Step 8 Now use the utility wdreg to install WinDriver's kernel module on the computer by typing the following:

```
wdreg -inf windrvr6.inf install
```

the response will be

```
install: completed successfully
```

- ✓ Step 9 Next install the DSP inf file by typing the following:

```
wdreg -inf c5509a.inf install
```

the response will be

```
install: completed successfully
```
- ✓ Step 10 Next install the software inf file type

```
wdreg -inf vc55r10.inf install
```

the response will be

```
install: completed successfully
```

Once the drivers and inf files are install the VC-55™ Vocoder Board can be connected to the PC via USB.

To verify correct operation of the board run the VC-55™ Program (vc55param.exe).

Installing USB driver INF files on Windows 98/Me:

If you are installing on a Windows98 PC then complete steps 1 through 7 and then

On Steps 8 through 10 substitute

```
wdreg16
```

in the command line instead of

```
wdreg
```

Here is an example for installation on Windows 98/Me, from the command line type

```
wdreg16 -inf windrvr6.inf install
```

On **Windows 98/Me** it is necessary to install the INF file for the VC-55™ Vocoder Board device manually, either via Windows **Add New Hardware Wizard** or **Upgrade Device Driver Wizard**, as explained below:

Windows Add New Hardware Wizard:

To activate the Windows **Add New Hardware Wizard**, connect the USB cable between the PC and the VC-55™ Vocoder Board, if the device is already connected, scan for hardware changes (**Refresh**). When Windows **Add New Hardware Wizard** appears, follow its installation instructions. When asked, point to the location of the INF file in your distribution package.

Windows Upgrade Device Driver Wizard:

To open Windows Device Manager:

From the **System Properties** window (right-click on **My Computer** and select **Properties**)

- ✓ select the **Device Manager** tab.
- ✓ Select your device from the **Device Manager** devices list
- ✓ choose the **Driver** tab and
- ✓ click the **Update Driver** button.

To locate your device in the Device Manager,
select **View devices by connection**.

For PCI devices, navigate to **Standard PC | PCI bus | <your device>**.

For USB devices, navigate to **Standard PC | PCI bus | PCI to USB Universal Host Controller (or any other controller you are using - OHCI/EHCI) | USB Root Hub | <your device>**.

Follow the instructions of the **Upgrade Device Driver Wizard** that opens. When asked, point to the location of the INF file in your distribution package.

Once the drivers and inf files are install the VC-55™ Vocoder Board can be connected to the PC via USB.

To verify correct operation of the board run the VC-55™ Vocoder Board Program (vc55param.exe).

Running the VC-55™ Vocoder Board Program vc55param.exe

The param utility program allows the operator to run the VC-55™-PR Vocoder Board. With this utility program the board can encode speech from either one of the analog inputs and decode a compressed voice file from another VC-55™-PR Vocoder Board via the RS-232 interface.

This program allows a user to:

- establish a real-time communication link to another vc-55
- set vocoder parameters
- store custom parameter setting into flash

Command Line Options

Text in brackets indicates the search text that the parser looks for.

Option	Name	Variables	Description
Board Options			
-F	Flash	none	Writes the current parameter setting into Flash. Once the parameters have been written to the flash memory then the VC-55 can be cycled through power without loosing the desired parameter settings.
Channel Options			
-c	Channel UART Rate	20	115,200 bps This is the fastest rate.
		40	57,600 bps
		60	38,400 bps
		80	28,800 bps
		100	23,040 bps
		120	19,200 bps This is the minimum rate that can run either the vocoder.
		240	9,600 bps This rate is not fast enough to run the Full-Rate vocoder.
-s	Slip_Mode	0	The [0] value sets slip mode to OFF. When off the vocoder is not making any adjustments for small fluctuations in the number of data samples.
		1	The [1] value sets slip mode to ON. When on the slip_mode is enabled the vocoder will compensate for small fluctuations in the number of data samples to maintain a high

			quality audio output.
-m	Chan_Rx_Min_Time	Between 0-636	Jitter Buffer Minimum time This time is adjustable to compensate for jitter on the channel interface. The minimum buffer time can be set between 0 and 636 ms. The option is set by multiplying the desired delay by 4000 (ex. A 1ms delay is set using the variable 4)
-M	Chan_Rx_Max_Time	Between 4-640	Jitter Buffer Maximum time This time is adjustable to compensate for jitter on the channel interface. The maximum buffer time can be set between 4 and 640 ms. The option is set by multiplying the desired delay by 4000 (ex. A 100ms delay is set using the variable 400)
Vocoder Options			
-r	Vocoder Rate	[f]ull-rate (default)	The vocoder has a total data bit rate of 7200 bps. Of these bits 4400 bps is voice data and 2800 bps is Forward Error Correction (FEC).
		[h]alf-rate	The Half-Rate vocoder in the VC-55™-PR Vocoder Board has a total data rate of 3600 bps. The Half-Rate includes 2450 bps of data and 1150 bps of FEC
-p	Encoder_Mode_Pin_Enable	0	The [0] value sets VC-55 board to run the vocoder rate as defined in the –r option of the vc55param program. If no –r option is included in the run command the the vocoder rate will be set to what is stored in Flash memory.
		1	The [1] value sets VC-55 board to run the vocoder rate as defined by the rate pin (no. 23 on J7). The pin default (no connection) is set to run the vocoder in half-rate mode.
-t	Side_Tone		default = -12dB, valid values= -6, -9, -12, -15, or -100 for off Note: Side Tone is used when a handset is connected to the VC-55. It sends a portion of the input signal from the microphone to the speaker of the handset to prevent the handset from sounding "dead".
-e	EncodeCmode	0	Disables both NS and DTX
		64	NS ENABLE FLAG Enables noise suppression in the encoder.
		2048	DTX ENABLE FLAG Enables silence frame generation in the encoder.
		2112	NS and DTX Enables both noise

			suppression (NS) and silence frame generation (DTX) in the encoder
		4096	Enables Tone Detection.
Audio Options			
-i	Analog Voice Input Source	[l]ine	Sets the audio input source to the stereo line in Jack J2
		[h]andset	Sets the audio input source to the Handset (RJ11) Jack J5

Table 4 vc55param variables

Notes:

- 1) Changes to EncodeModePinEnable, EncodeMode, SlipMode, ChanRxMinTime, and ChanRxMaxTime take effect the next frame.
- 2) Changes to EncodeSource, EncodeCmode, SideTone, ChannelUartRate require Flash and reset to take effect.
- 3) To program settings into flash you have to enter the parameters to change along with the -F option.
Example: To set the baud rate 28,800 into the memory the correct command is

```
vc55param -c 80 -F
```

then verify the data by running vc55param (with no command line options) twice (SEE NOTE BELOW)

```
vc55param
vc55param
```

Once you do this and reset the board it will remain in memory.

NOTE: When running the vc55param program for the first time after a reset or after applying power, the settings printed out to screen may contain erroneous data. Therefore, it is always best to run vc55param a couple of times (with no command line options) before verifying the actual parameter settings as set in flash.

Running the Program

The vc55param is run from a DOS window. Go to the directory that contains the vc55param.exe file and type in vc55param the program will run and print to screen the current status of the board. The response will contain the following items:

Parameter Option Name	Variable Description
vc55 Status Device=0	This is a device number identification. If two or more VC-55s are connected to USB ports at the same time then the vc55param program will write to both devices. This is useful if you want to bulk load the same parameters or see the settings for all boards. However, when more than one board is connected to a USB you do not have individual control of setting different parameters for each

	board.	
Encode_Mode	APCO (Full Rate)	Half-Rate (Half-Rate)
Slip_Mode	1 (Slip Mode On)	0 (Slip Mode Off)
EncodeCmode	0(NS & DTX off); 64(NS on); 2048 (DTX on); 2112 (NS & DTX on)	
Chan_Rx_Min_Time	0 -636 (The jitter buffer delay as set in the parameters)	
Chan_Rx_Max_Time	4 - 640 (The jitter buffer delay as set in the parameters)	
Encode_Source	1 (Handset)	2 (Line -In)
Channel_Uart_Rate	20 – 240 (115,200 to 9,600 as set in the parameters)	
Sync_Err_Rate	Sync error rate is the bit error rate in the sync and rate words of the packet multiplied by 512	
Lost_Sync_Rate	The number of times the channel has lost sync	
Lost_Packets	The number of packets not received from across the channel. This could be due problems in the channel or for clock drift between the two systems.	
Dropped_Packets	The number of packets that got dropped and not processed by the decoder because it could not keep up with the input.	
DecodeErrRate	estimated bit error rate in FEC protected bits of packet *2^17	

Table 5 vc55param output to screen

Executing the vc55param program without setting any of the parameter options will result in a print to screen of all the current settings information stored in the VC-55™ -PR Vocoder Board 's flash memory.

VC-55™ -PR Vocoder Board Status

The VC-55™-PR Vocoder Board LED Status is designed to conveniently display the current conditions for Audio I/O, vocoder and communications channel to the operator.

The top two LEDS of the VC-55™-PR Vocoder Board indicate the current running condition. The LCD indicators indicate the status of the board

LED ID	Location	Description (when LED ON)
PWR	D2	Power Applied
LED 1	D12	Lost Packet
LED 2	D11	Encoder is running.
LED 3	D10	Decoder is running.
LED 4	D1	Channel is Synchronized

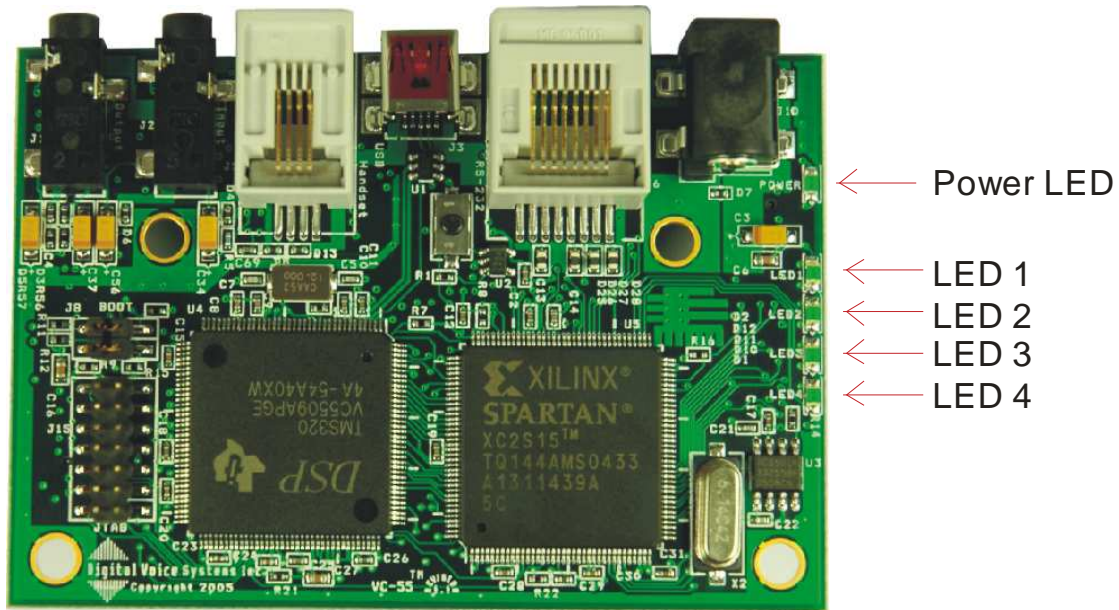

Figure 5

The LED D2 on the VC-55™-PR Vocoder Board indicates power is ON. The VC-55™-PR Vocoder Board is synch'd with another VC-55™-PR Vocoder Board when LED D12 is active.. In this condition the unit is ready to process data through the encoder or decoder. When the unit is processing data through the encoder or decoder LED D10 and LED D11 respectively are active.

SECTION 4

Channel Interface



Vocoder Board Channel Basic Operation

All channel packets contain data (coded speech) that is sent to the decoder to synthesize speech. When a Channel packet is received the Vocoder Board decodes the packet and plays the synthesized speech out the selected analog interface. At the same time the VC-55™ -PR Vocoder board can encode the speech from the analog input and send it across the channel to be decoded by another VC-55™ -PR .

Data Structure

Data packets sent as byte-aligned frames over the asynchronous RS-232 Uart Serial interface. This helps maintains compatibility with asynchronous 8N1 framing and synchronization if channel errors exist.

The first byte is the sync element (byte 0). It holds the 8-bit identification of the start of the packet. The packet sync value of the first byte is always the same. The second 8 bit byte will either be 0x0F or 0xF0 indicating the encoded rate. The rest of the packet is the compressed voice data. An “x” is used in all the tables in this description to indicate that a bit can take a value of 0 or 1.

Packet Structure			
Byte	Parameter Name	Bits 7 6 5 4 3 2 1 0	Hex Value
0	sync	0 1 0 1 0 1 1 0	0x56
1	rate	x x x x x x x x	0x0F or 0xF0
2	Compressed voice bits 0-7	x x x x x x x x	0xXX
...	Compressed voice bits 8-15
...
10	Compressed voice bits 64-71	Last Byte when running Half-Rate Mode	
...
...	Compressed voice bits 72-79	x x x x x x x x	0xXX
...
19	Compressed voice bits 136-143	Last Byte when running Full-Rate Mode	

Table 6 Packet Structure

rate

Byte 1 is used to set the rate information of the data in the packet.

The AMBE APCO PROJECT 25 coder runs in either one of two rates as shown in Table 7 Vocoder Rate .

rate (vocoder rate)		
	Byte 1 7 6 5 4 3 2 1 0	Hex Value
Full-Rate (7200 bps)	1 1 1 1 0 0 0 0	0xF0
Half-Rate (3600 bps)	0 0 0 0 1 1 1 1	0x0F

Table 7 Vocoder Rate Elements

Rate	Number of Compressed voice data bits	Total Number of channel data bytes
Rate (7200 bps)	144	20
Half-Rate (3600 bps)	72	11

Table 8 Rates Description

Specifications



Introduction

This section contains hardware Specifications of the VC-55™ Vocoder Board.

NOTE: All values are typical unless noted otherwise.

All specifications subject to change.

Board Connections

Channel Connection

Serial Port	
Type	RS-232 asynchronous
Connector	RJ-45

VC-55™- PR Vocoder Board RS 232 Serial Port Pin Out	
Pin Number	Name
1	Not Used
2, 5, 6, 8	Connected internally to Ground
7	Tx Channel out
3	Not Used
4	Rx Channel In

Table 9 RS-232 Serial Port Pin Out

Audio I/O Connections

Line In	
Type	Single-ended Input
Connector	female 3.5mm Audio Jack
Maximum Input Level:	1.41 Volts RMS
Input Impedance	10 kOhms nominal
Bandwidth	20 Hz to 4 kHz (up to 48 kHz. available)
D/A Resolution	16 bits
D/A Sampling Rate:	8 kHz (up to 96kHz. available)
SNR (Non-Weighted)	81 dB

Line Out	
Type:	Single-ended Output
Connector:	female 3.5mm Audio Jack
Maximum Output Level	1.0 Volt RMS
Output Impedance:	<50 Ohms
Bandwidth:	20 Hz to 3.6 kHz (up to 48 kHz. available)
A/D Resolution:	16 bits
SNR (Non-Weighted)	84 dB
A/D Sampling Rate:	8 kHz (up to 96kHz. available)
Minimum Load	10k Ohms nominal

Handset:	
Type:	Single-ended
Connector:	RJ 4P4C
Bandwidth:	20 Hz to 4 kHz
A/D Sampling Rate:	8 kHz
A/D Resolution:	16 bits

VC-55™- Handset Pin Out (as viewed from the board)	
Pin Number	Name
1 and 2	Connected internally to Ground
3	Speaker Out
4	Microphone In/DC Mic Bias out

Table 10 RS-232 Serial Port Pin Out

USB Connection

J3 USB	
Pin Number	Name
1	No Connection
2	USBA (D-)1
3	USBA2 (D+)
4	No Connection
5	Ground

Electrical Input

J10 Power	
Pin Number	Name
Center	+5 Volts DC
Shield	Ground

DC Power	
Input Voltage	5 Volts or 3.3 Volts DC
Input Current	250 ma @ 5V / 3.3 VDC

Mechanical

Mechanical	
Weight	1.2 oz. (with connectors installed)
Size (W X D X H)	3.1875" X 2.1875"

SECTION 6

Support



DVSI Technical Support

If you have any problems with the VC-55™- PR Vocoder Board Voice Codec Board or have questions about its operation, please contact:

Digital Voice Systems, Inc.
234 Littleton Road
Westford, MA 01886 USA

Phone: (978) 392-0002
Fax: (978) 392-8866

email: info@dvsinc.com
web: www.dvsinc.com

History of Revisions			
Revision Number	Date of Revision	Description	Pages
1.1	February 2009	Removed Preliminary	all

NOTES